

MACHINE VISE
SCALE 1 : 1

PARTS LIST

| ITEM | QTY | PART NUMBER | MATERIAL | DESCRIPTION |
|------|-----|--------------------------------------|-------------------|---|
| 1 | 1 | BASE | CAST,IRON | |
| 2 | 1 | SLIDING JAW | CAST,IRON | |
| 3 | 2 | JAW PLATE | SAE 3140 | |
| 4 | 1 | WISE SCREW | SAE 3140 | |
| 5 | 1 | COLLAR | SAE 1020 | |
| 6 | 1 | SPECIAL KEY | SAE 1020 | |
| 7 | 1 | HANDLE ROD | COLD ROLLED STEEL | |
| 8 | 2 | HANDLE BALL | SAE 1020 | |
| 9 | 2 | SLIDE KEY | SAE 1020 | |
| 10 | 2 | SET SCREW | STEEL, CAST | |
| 11 | 4 | ANSI B18.6.3 - 1/4-20 x 3/4, SFCHMSI | STEEL, MILD | SLOTTED FLAT COUNTERSUNK HEAD MACHINE SCREW |
| 12 | 2 | TAPER PIN | STEEL, MILD | #000 TAPER PIN |

GENERAL NOTES:

FILLEDS AND ROUNDS R.125 UNLESS OTHERWISE NOTED

LEGEND:

- ∅ DIAMETER
- R RADIUS
- ° DEGREES
- ┌ COUNTER BORE
- ∇ DEPTH
- ∨ COUNTER SINK



DIGITAL DESIGN
GRAPHICS
TECHNOLOGY

WWW.DDGT.NET

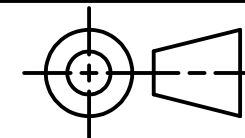

TOLERANCES UNLESS SPECIFIED:
 DECIMAL INCHES
 X = ±.020
 XX = ±.010
 XXX = ±.005
 FRACTIONAL ±1/64"
 ANGLE ±1 DEGREE
 SURFACES ³²✓

COURSE: DDGT240

INVENTOR DRAWING NAME
MACHINE VISE

FIG #: 14-71

DRAFTER: W.VALLADARES

DATE: 9/25/2019

SCALE: AS NOTED

PAGE #: 1 OF 5

| PARTS LIST | | |
|------------|-----|---|
| ITEM | QTY | PART NUMBER |
| 1 | 1 | BASE |
| 3 | 1 | JAW PLATE |
| 11 | 2 | ANSI B18.6.3 - 1/4-20 x 3/4, SFCHMSI(1) |

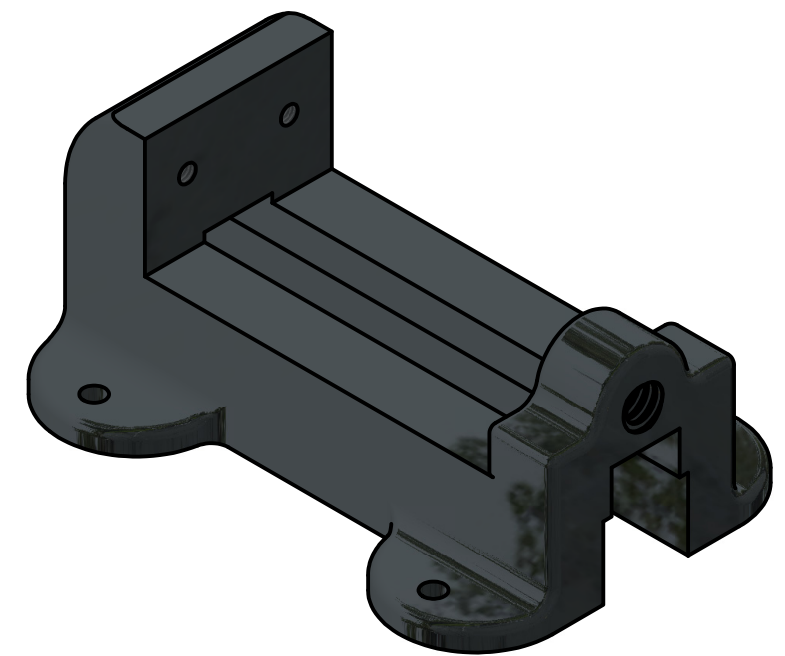
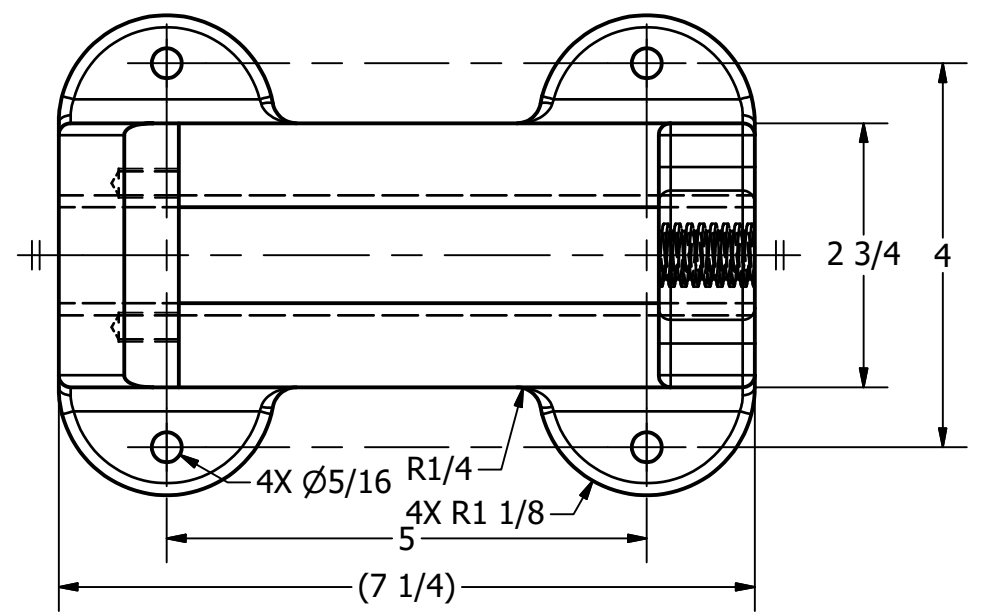

SCALE 1 / 2

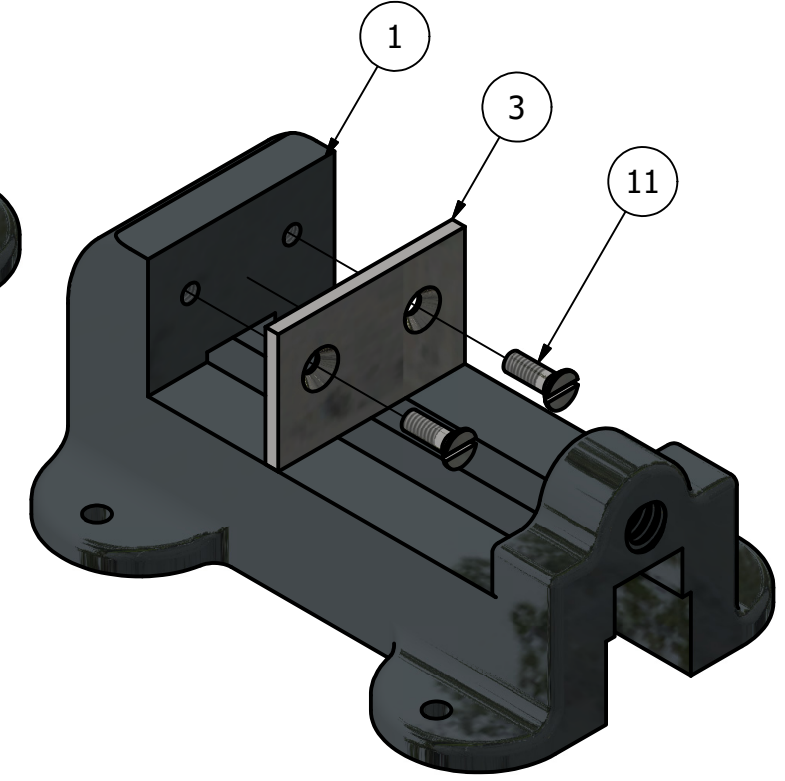

MACHINE VISE STEP ONE
SCALE 1 / 2

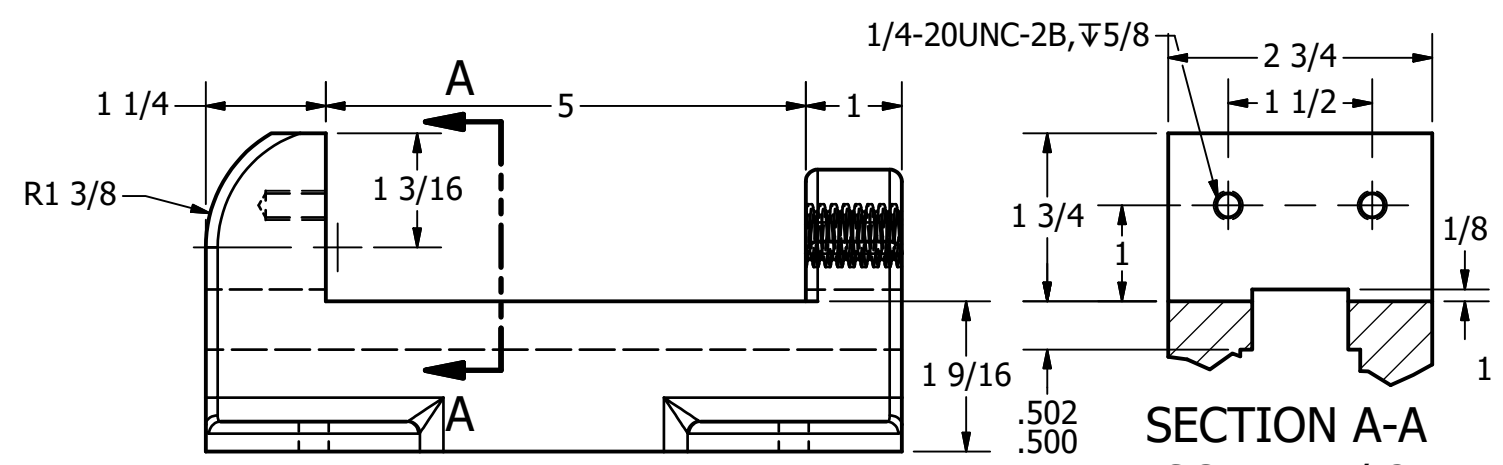

BASE
SCALE 1 / 2

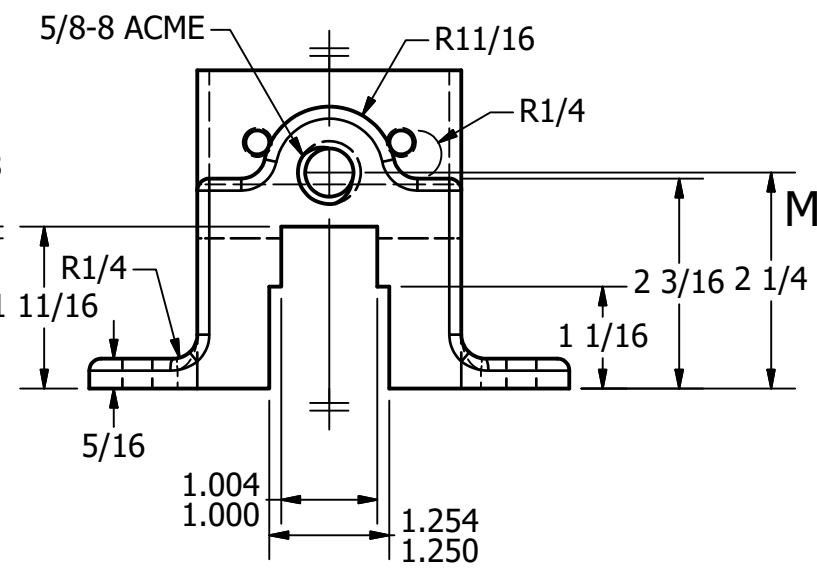

SECTION A-A
SCALE 1 / 2

GENERAL NOTES:
FILLEDS AND ROUNDS R.125 UNLESS OTHERWISE NOTED

- LEGEND:**
- Ø DIAMETER
 - R RADIUS
 - ° DEGREES
 - COUNTER BORE
 - ∇ DEPTH
 - ✓ COUNTER SINK



DIGITAL DESIGN
GRAPHICS
TECHNOLOGY

WWW.DDGT.NET

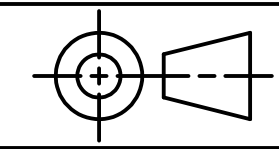

TOLERANCES UNLESS SPECIFIED:
DECIMAL INCHES
X = ±.020
XX = ±.010
XXX = ±.005
FRACTIONAL ±1/64"
ANGLE ±1 DEGREE
SURFACES 32 ✓

| | |
|-----------------------|--------------|
| COURSE: | DDGT240 |
| INVENTOR DRAWING NAME | MACHINE VISE |
| FIG #: | 14-71 |
| DRAFTER: | W.VALLADARES |
| DATE: | 9/25/2019 |
| SCALE: | AS NOTED |
| PAGE #: | 2 OF 5 |

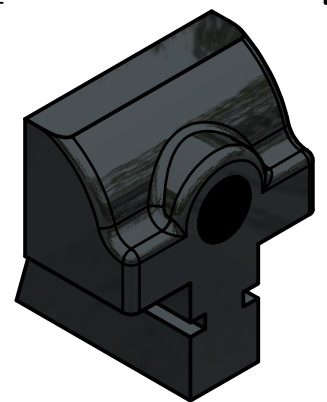
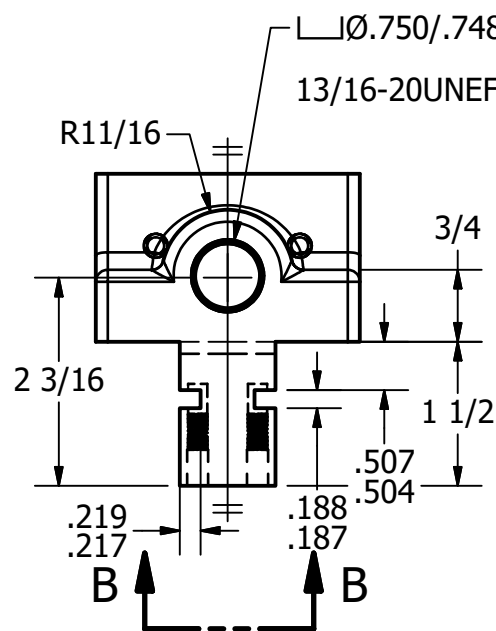

SLIDING JAW
SCALE 1 / 2

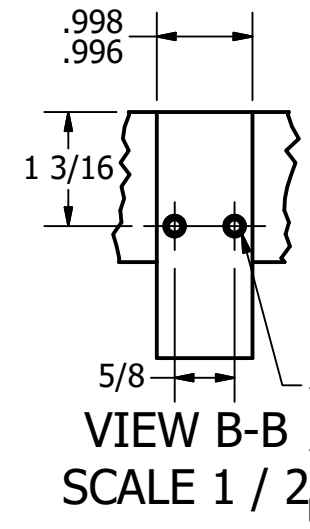

VIEW B-B
SCALE 1 / 2

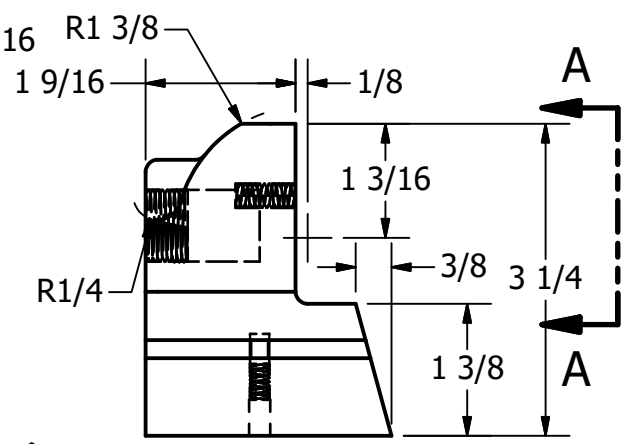

VIEW A-A
SCALE 1 / 2

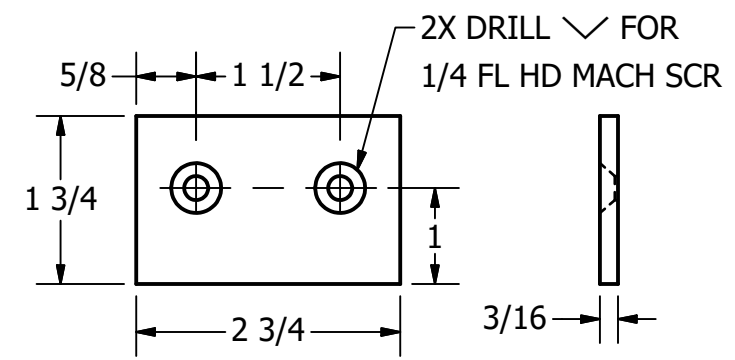

LEGEND:
 Ø DIAMETER
 R RADIUS
 ° DEGREES
 □ COUNTER BORE
 ▽ DEPTH
 √ COUNTER SINK

| PARTS LIST | | |
|------------|-----|---|
| ITEM | QTY | PART NUMBER |
| 2 | 1 | SLIDING JAW |
| 3 | 1 | JAW PLATE |
| 11 | 4 | SLOTTED FLAT COUNTERSUNK HEAD MACHINE SCREW |

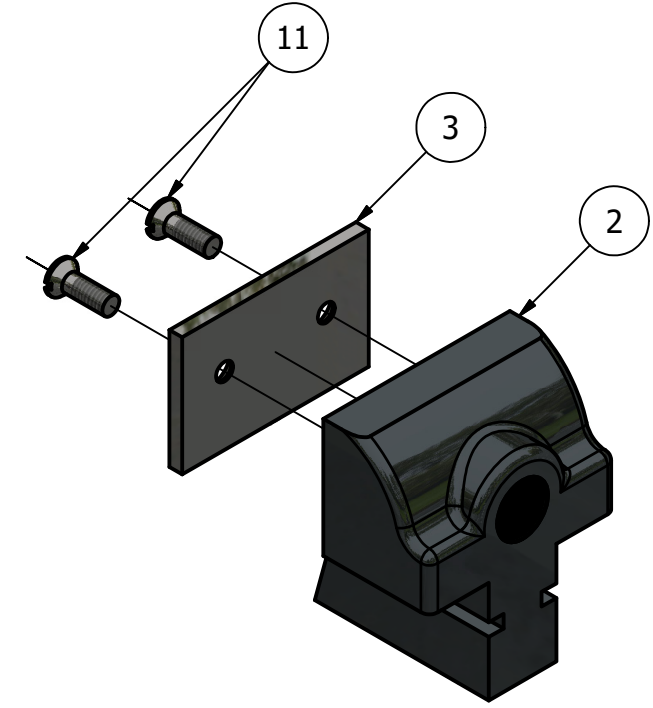

MACHINE VISE STEP 2
SCALE 1 / 2

GENERAL NOTES:

FILLEDS AND ROUNDS R.125 UNLESS OTHERWISE NOTED



DIGITAL DESIGN
 GRAPHICS
 TECHNOLOGY

WWW.DDGT.NET

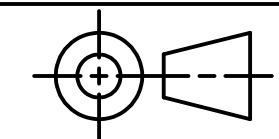

TOLERANCES UNLESS SPECIFIED:
 DECIMAL INCHES
 X = ±.020
 XX = ±.010
 XXX = ±.005
 FRACTIONAL ±1/64"
 ANGLE ±1 DEGREE
 SURFACES 32 ✓

| | |
|-----------------------|--------------|
| COURSE: | DDGT240 |
| INVENTOR DRAWING NAME | MACHINE VISE |
| FIG #: | 14-71 |
| DRAFTER: | W.VALLADARES |
| DATE: | 9/25/2019 |
| SCALE: | AS NOTED |
| PAGE #: | 3 OF 5 |

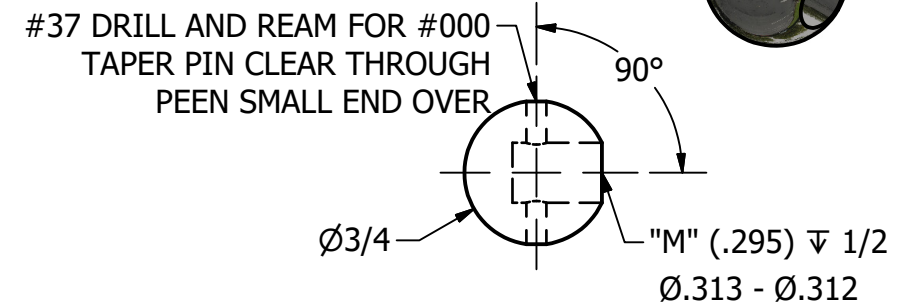
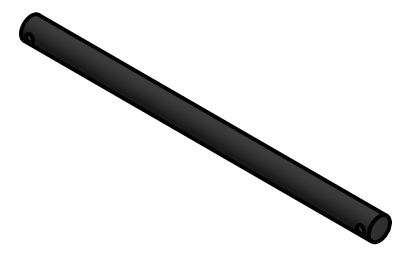
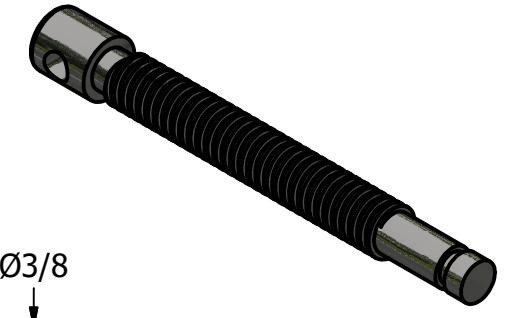
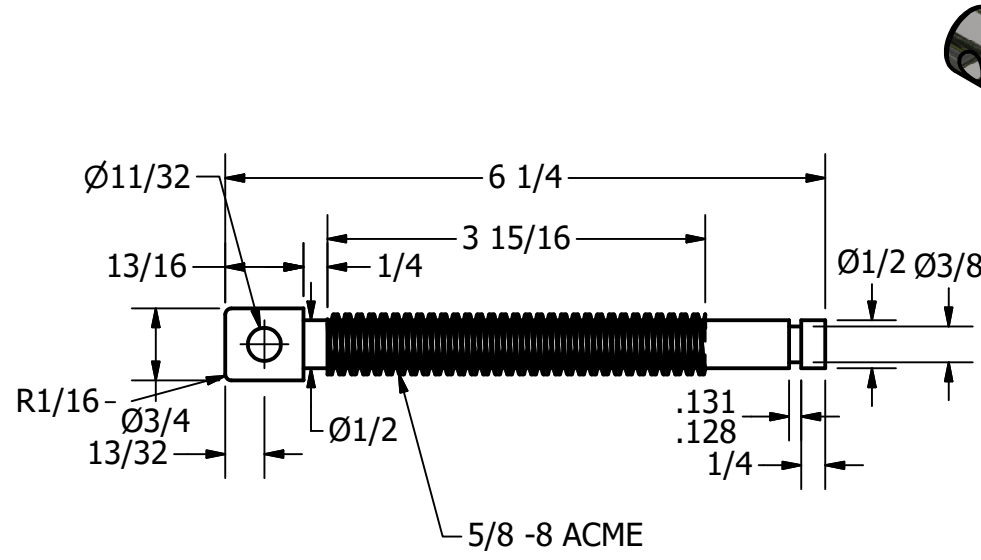

LEGEND:

- Ø DIAMETER
- R RADIUS
- ° DEGREES
- ┌ COUNTER BORE
- ∇ DEPTH
- ✓ COUNTER SINK

| PARTS LIST | | |
|------------|-----|-------------|
| ITEM | QTY | PART NUMBER |
| 4 | 1 | WISE SCREW |
| 7 | 1 | HANDLE ROD |
| 8 | 2 | HANDLE BALL |
| 12 | 2 | TAPER PIN |

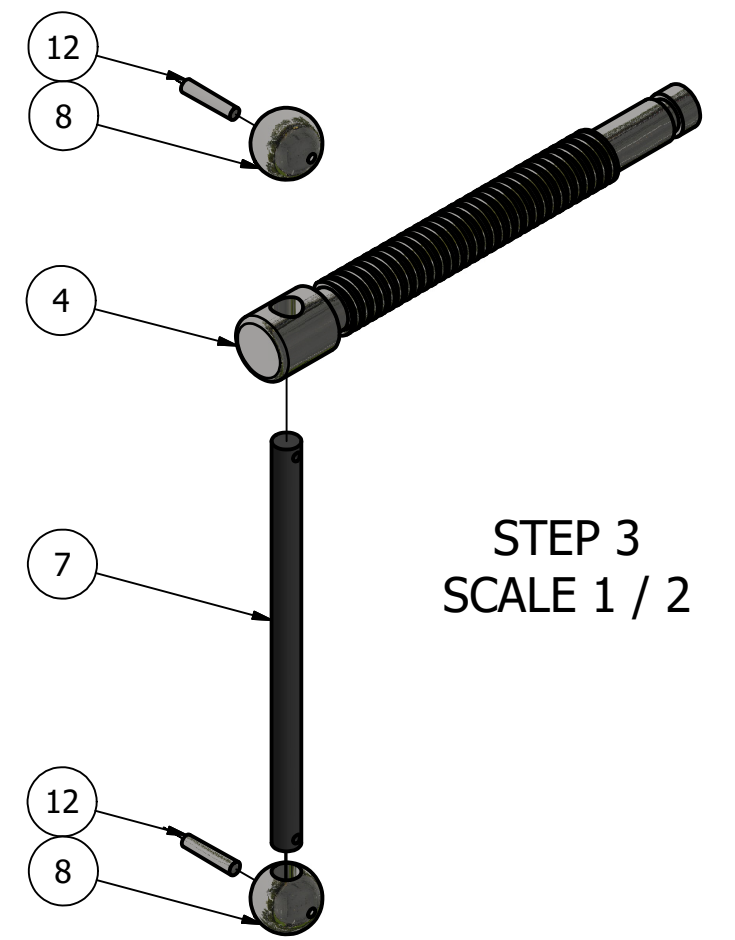

STEP 3
SCALE 1 / 2

HANDLE ROD
SCALE 1 / 2

HANDLE BALL
SCALE 1 : 1

GENERAL NOTES:
FILLEDS AND ROUNDS R.125 UNLESS OTHERWISE NOTED



DIGITAL DESIGN
GRAPHICS
TECHNOLOGY

WWW.DDGT.NET

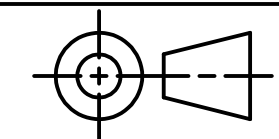

TOLERANCES UNLESS SPECIFIED:
DECIMAL INCHES
X = ±.020
XX = ±.010
XXX = ±.005
FRACTIONAL ±1/64"
ANGLE ±1 DEGREE
SURFACES 32 ✓

| | |
|-----------------------|--------------|
| COURSE: | DDGT240 |
| INVENTOR DRAWING NAME | MACHINE VISE |
| FIG #: | 14-71 |
| DRAFTER: | W.VALLADARES |
| DATE: | 9/25/2019 |
| SCALE: | AS NOTED |
| PAGE #: | 4 OF 5 |

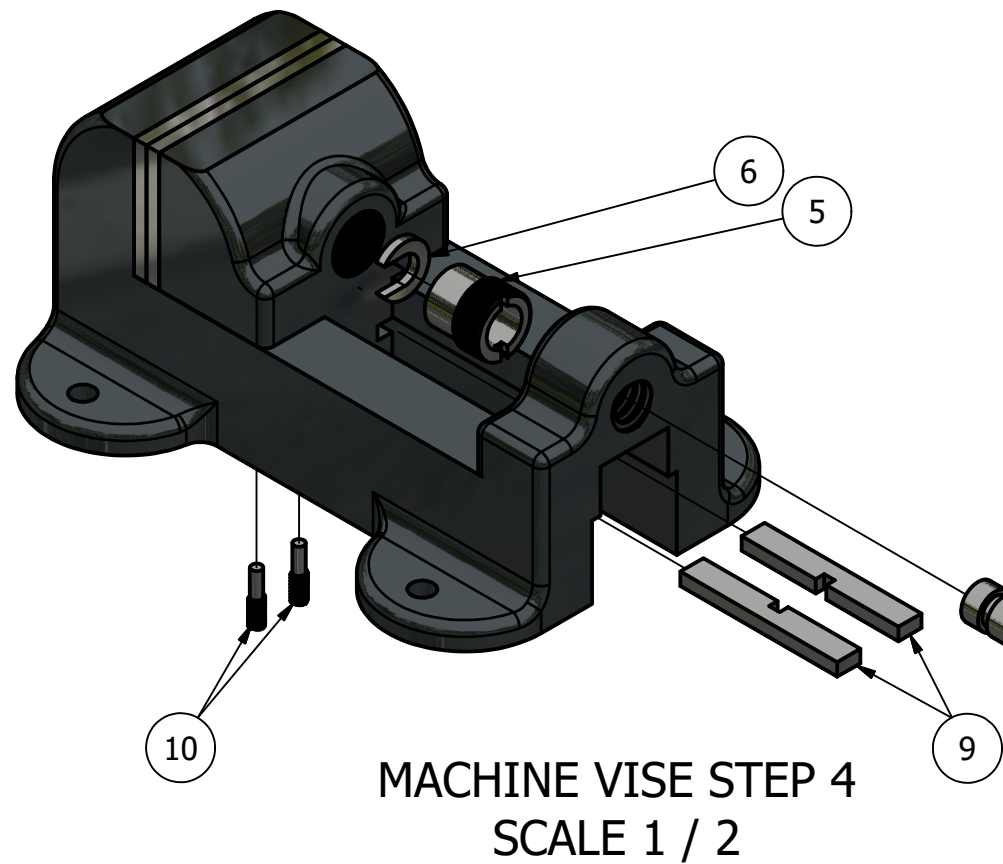

MACHINE VISE STEP 4
SCALE 1 / 2

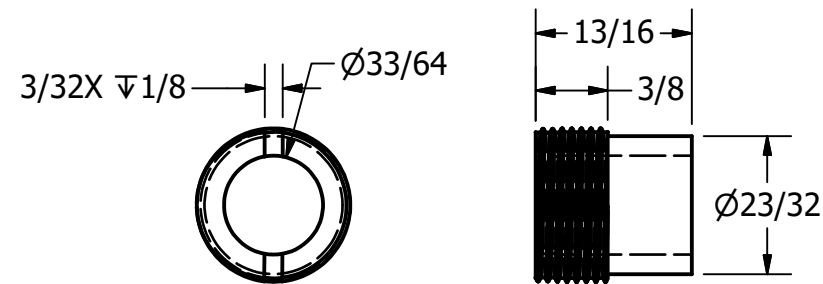

COLLAR
SCALE 1 : 1

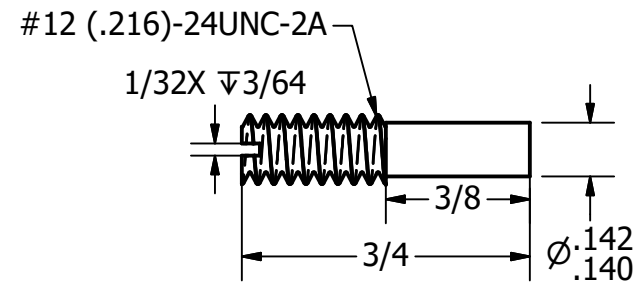

SET SCREW
SCALE 2 : 1

LEGEND:

- ∅ DIAMETER
- R RADIUS
- ° DEGREES
- COUNTER BORE
- ∇ DEPTH
- ✓ COUNTER SINK

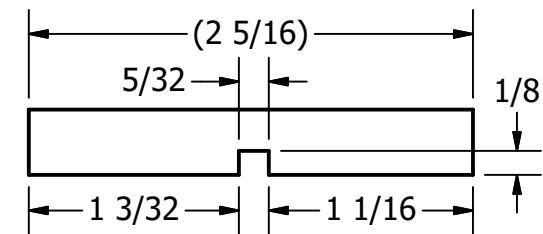

SLIDE KEY
SCALE 1 : 1

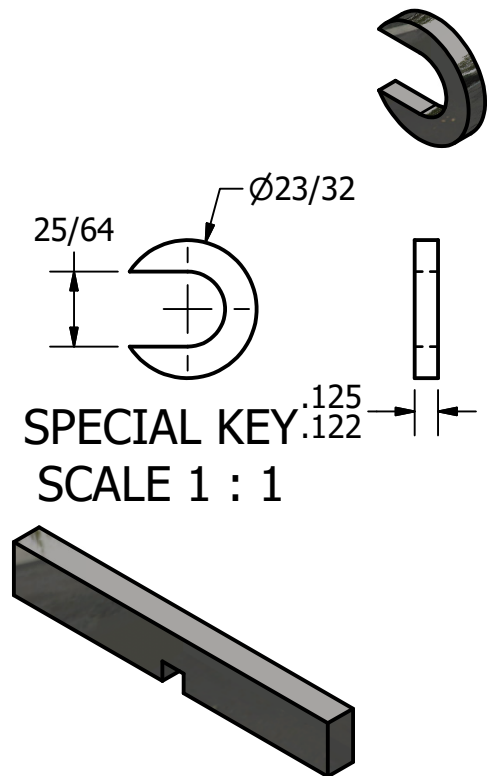

SPECIAL KEY
SCALE 1 : 1

| PARTS LIST | | |
|------------|-----|-------------|
| ITEM | QTY | PART NUMBER |
| 5 | 1 | COLLAR |
| 6 | 1 | SPECIAL KEY |
| 9 | 2 | SLIDE KEY |
| 10 | 2 | SET SCREW |

GENERAL NOTES:

FILLEDS AND ROUNDS R.125 UNLESS OTHERWISE NOTED



DIGITAL DESIGN
GRAPHICS
TECHNOLOGY

WWW.DDGT.NET

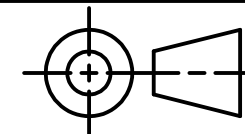

TOLERANCES UNLESS SPECIFIED:
DECIMAL INCHES
X = ±.020
XX = ±.010
XXX = ±.005
FRACTIONAL ±1/64"
ANGLE ±1 DEGREE
SURFACES \checkmark 32

COURSE: DDGT240

INVENTOR DRAWING NAME
MACHINE VISE

FIG #: 14-71

DRAFTER: W.VALLADARES

DATE: 9/25/2019

SCALE: AS NOTED

PAGE #: 5 OF 5